

Power-Stud™ Wedge Expansion Anchor

PRODUCT DESCRIPTION

The Power-Stud anchor is a fully threaded, torque-controlled, wedge expansion anchor. It is available in threaded, rod hanger and tie-wire versions suitable for applications in solid concrete and grout-filled concrete masonry. The carbon steel threaded version is suitable for a variety of applications. The drill bit diameter necessary for proper installation is the same as the anchor diameter.

GENERAL APPLICATIONS AND USES

- Lighting Standards and Base Plates
- Sills and Support Ledgers
- Structural Anchorage
- Retrofit Projects and Machinery Anchorage

FEATURES AND BENEFITS

- + Fully threaded, heavy and medium duty all-purpose anchor
- + Nominal drill bit diameter same as anchor diameter (threaded version)
- + Length ID stamped on each threaded anchor
- + Anchors can be installed through the fixture, hole spotting not required
- + Chamfered impact section prevents damage to threads
- + Length of holes can be over-drilled or bottomless
- + Clip design prevents spinning during installation

APPROVALS AND LISTINGS

Tested in accordance with ASTM E488 and AC01 criteria
 FM Global (Factory Mutual) – File No. J.I. OK3A9.AH (see ordering information)
 Underwriters Laboratory (UL Listed) – File No. EX1289 (see ordering information)
 Federal GSA Specification
 Meets the descriptive and proof load requirements of CID A-A-1923A, Type 4 (threaded version)
 CalTrans listing for “Stud Mechanical Expansion Anchors”

GUIDE SPECIFICATIONS

CSI Divisions: 03151-Concrete Anchoring, 04081-Masonry Anchorage and 05090-Metal Fastenings. Expansion anchors shall be Power-Stud as supplied by Powers Fasteners, Inc., Brewster, NY.

SECTION CONTENTS	Page No.
General Information	1
Installation Specifications	2
Material Specifications.....	4
Performance Data	5
Design Criteria.....	9
Ordering Information	13

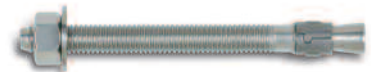

Threaded Power-Stud Assembly



Rod Hanger Power-Stud



Tie-Wire Power-Stud

HEAD STYLES

- Threaded Stud
- Rod Hanger
- Tie-Wire

ANCHOR MATERIALS

Zinc Plated Carbon Steel

ANCHOR SIZE RANGE (TYP.)

1/4" diameter through 1-1/4" diameter

SUITABLE BASE MATERIALS

Normal-weight Concrete
 Structural Lightweight Concrete
 Grouted Concrete Masonry
 (uncracked base materials)

INSTALLATION SPECIFICATIONS

Mechanically Galvanized Carbon Steel Power-Stud

Dimension	Anchor Diameter, <i>d</i>							
	1/4"	3/8"	1/2"	5/8"	3/4"	7/8"	1"	1-1/4"
ANSI Drill Bit Size, d_{bit} (in.)	1/4	3/8	1/2	5/8	3/4	7/8	1	1-1/4
Fixture Clearance Hole, d_h (in.)	5/16	7/16	9/16	11/16	13/16	15/16	1-1/8	1-3/8
Thread Size (UNC)	1/4-20	3/8-16	1/2-13	5/8-11	3/4-10	7/8-9	1-8	1 1/4-7
Nut Height (in.)	7/32	21/64	7/16	35/64	41/64	3/4	55/64	1 1/16
Washer O.D., d_w (in.)	5/8	13/16	1 1/16	1 3/4	2	2 1/4	2 1/2	3
Wrench Size (in.)	7/16	9/16	3/4	15/16	1 1/8	1 5/16	1 1/2	1 7/8
Tightening Torque, T_{inst} (ft-lbs)	8	28	60	90	175	250	300	450

Tightening torque is listed for anchors installed in normal-weight concrete. Consult performance data tables for other base materials.

Rod Hanger Power-Stud

Dimension	Threaded Rod Anchor Diameter, <i>d</i>
	3/8"
Outside Diameter, (in.)	1/2
ANSI Drill Bit Size, d_{bit} (in.)	1/2
Internal Thread Size (UNC)	3/8 - 16

Tie-Wire Power-Stud

Dimension	Anchor Diameter, <i>d</i>
	1/4"
ANSI Drill Bit Size, d_{bit} (in.)	1/4
Tie-Wire Hole Size (in.)	9/32
Head Height (in.)	3/4

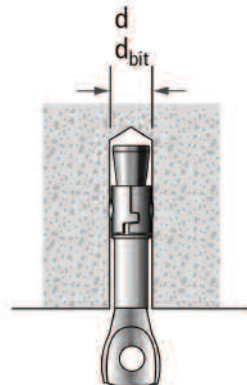
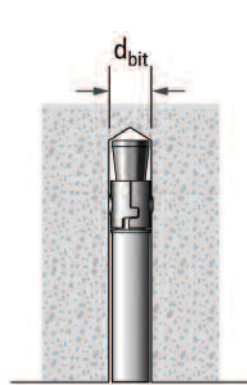
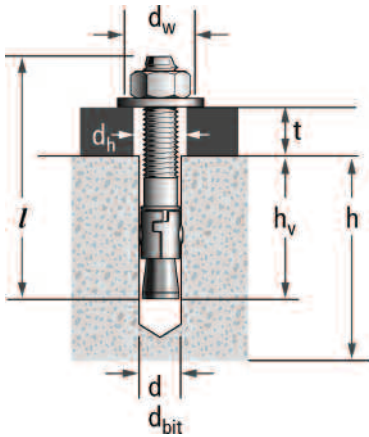

Nomenclature

- d* = Diameter of anchor
- d_{bit} = Diameter of drill bit
- d_h = Diameter of fixture clearance hole
- d_w = Diameter of washer
- h* = Base material thickness.
The minimum value of *h* should be $1.5h_v$, or 3" whichever is greater
- h_v = Minimum embedment depth
- l* = Overall length of anchor
- t* = Fixture thickness

INSTALLATION PROCEDURES

Threaded Stud Version

Using the proper diameter bit, drill a hole into the base material to a depth of at least 1/2" or one anchor diameter deeper than the embedment required. The tolerances of the drill bit used must meet the requirements of ANSI Standard B212.15



Blow the hole clean of dust and other material. Do not expand the anchor prior to installation

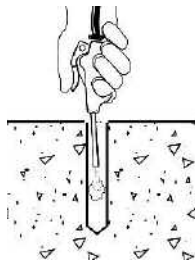

Position the washer on the anchor and thread on the nut. Drive the anchor through the fixture into the anchor hole until the nut and washer are firmly seated against the fixture. Be sure the anchor is driven to the required embedment depth.

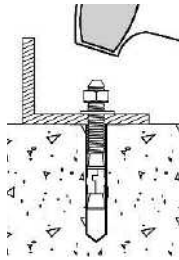

Tighten the anchor by turning the nut 3 to 5 turns past finger tight or by applying the guide installation torque from the finger tight position.

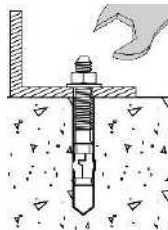

Rod Hanger Version

Using the proper diameter bit, drill a hole into the base material to a depth of at least 1/2" or one anchor diameter deeper than the embedment required. The tolerances of the drill bit used must meet the requirements of ANSI Standard B212.15



Blow the hole clean of dust and other material. Do not expand the anchor prior to installation

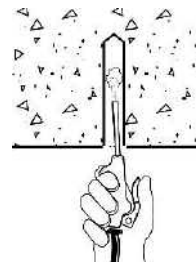

Thread the anchor onto the rod to be used along with a nut and washer. Drive the anchor into the hole until the anchor is at the required embedment depth. The anchor body should be recessed in the hole.

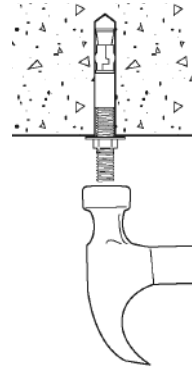

Run the nut and washer up to the concrete surface and tighten the anchor by turning the nut 3 to 5 turns past finger tight position.



Tie-Wire Version

Using the proper diameter bit, drill a hole into the base material to a depth of at least 1/2" or one anchor diameter deeper than the embedment required. The tolerances of the drill bit used must meet the requirements of ANSI Standard B212.15

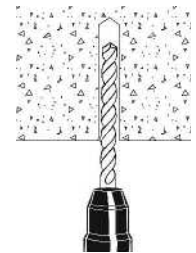

Blow the hole clean of dust and other material. Do not expand the anchor prior to installation

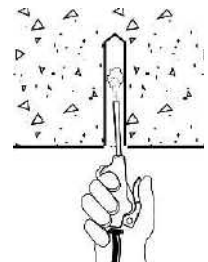

Drive the anchor into the hole until the head is firmly seated against the base material. Be sure the anchor is driven to the required embedment depth.

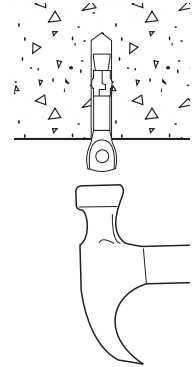

Set the anchor with a prying action using a claw hammer.

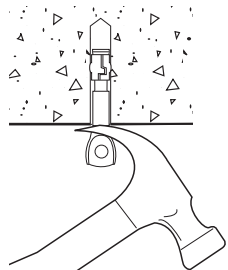

MATERIAL SPECIFICATIONS

Anchor Component	Carbon Steel Power-Stud
Anchor Body	AISI 1018 (1/4" – 3/4", lengths up to 7")
	AISI 12L14 (7/8" – 1-1/4" and all lengths over 7")
Nut	Carbon Steel, ASTM A563, Grade A
Washer	AISI 1010 Carbon Steel, Meets Dimensional Requirements of ANSI/ASME 18.22.1, Type A Plain
Expansion Wedge	Tempered AISI 1010 Carbon Steel
Zinc Plating	ASTM B633, SC1, Type III (Fe/Zn 5)

Anchor Component	Rod Hanger Power-Stud	Tie-Wire Power-Stud
Anchor Body	AISI 12L14 Carbon Steel	AISI 1008 Carbon Steel
Expansion Wedge	Tempered AISI 1010 Carbon Steel	Tempered AISI 1010 Carbon Steel
Zinc Plating	ASTM B633, SC1, Type III (Fe/Zn 5)	ASTM B633, SC1, Type III (Fe/Zn 5)

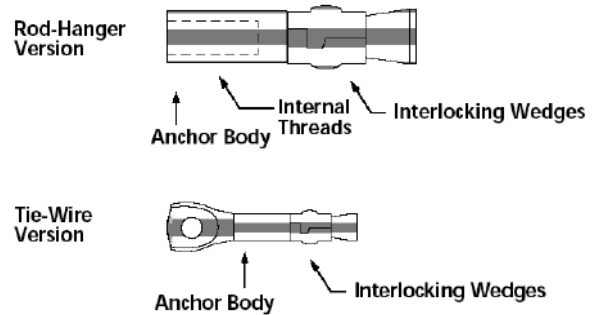
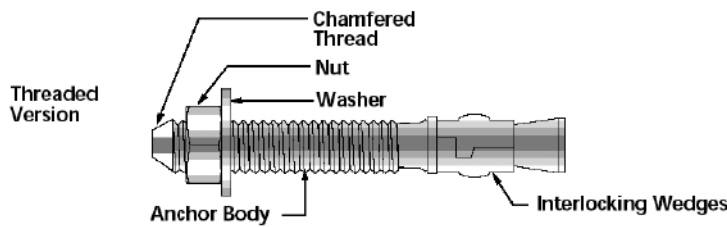

Length Identification (threaded version)

Mark	◆	■	A	B	C	D	E	F	G	H	I
From	1/2"	1"	1-1/2"	2"	2-1/2"	3"	3-1/2"	4"	4-1/2"	5"	5-1/2"
Up to but not including	1"	1-1/2"	2"	2-1/2"	3"	3-1/2"	4"	4-1/2"	5"	5-1/2"	6"

Mark	J	K	L	M	N	O	P	Q	R	S	T
From	6"	6-1/2"	7"	7-1/2"	8"	8-1/2"	9"	9-1/2"	10"	11"	12"
Up to but not including	6-1/2"	7"	7-1/2"	8"	8-1/2"	9"	9-1/2"	10"	11"	12"	13"

PERFORMANCE DATA

Ultimate Load Capacities for Carbon Steel Power-Stud in Normal-Weight Concrete^{1,2}

Anchor Diameter <i>d</i> in. (mm)	Minimum Embedment Depth <i>h_v</i> in. (mm)	Minimum Concrete Compressive Strength (<i>f'_c</i>)					
		2,000 psi (13.8 MPa)		4,000 psi (27.6 MPa)		6,000 psi (41.4 MPa)	
		Tension lbs. (kN)	Shear lbs. (kN)	Tension lbs. (kN)	Shear lbs. (kN)	Tension lbs. (kN)	Shear lbs. (kN)
1/4 (6.4)	1 1/8 (28.6)	1,240 (5.6)	1,580 (7.1)	1,440 (6.5)	1,620 (7.3)	1,740 (7.8)	1,620 (7.3)
	1 1/2 (38.1)	1,635 (7.4)	1,580 (7.1)	2,080 (9.4)	1,620 (7.3)	2,100 (9.5)	1,620 (7.3)
	2 (50.8)	1,900 (8.6)	1,580 (7.1)	2,080 (9.4)	1,620 (7.3)	2,100 (9.5)	1,620 (7.3)
	2 3/4 (69.9)	2,340 (10.5)	1,655 (7.4)	2,360 (10.6)	2,070 (9.3)	2,535 (11.4)	2,080 (9.4)
3/8 (9.5)	1 5/8 (41.3)	1,920 (8.6)	3,560 (16.0)	3,040 (13.7)	3,760 (16.9)	3,040 (13.7)	3,760 (16.9)
	2 (50.8)	2,800 (12.6)	3,560 (16.0)	3,850 (17.3)	3,760 (16.9)	4,075 (18.3)	3,760 (16.9)
	3 (76.2)	4,100 (18.5)	3,560 (16.0)	6,020 (27.1)	3,760 (16.9)	6,025 (27.1)	3,760 (16.9)
	4 1/4 (108.0)	5,045 (22.7)	3,840 (17.3)	6,020 (27.1)	5,185 (23.3)	6,025 (27.1)	5,185 (23.3)
1/2 (12.7)	2 1/4 (57.2)	3,440 (15.5)	6,540 (29.4)	5,560 (25.0)	6,800 (30.6)	6,540 (29.4)	6,800 (30.6)
	3 (76.2)	5,100 (23.0)	6,540 (29.4)	8,160 (36.7)	6,800 (30.6)	9,200 (41.4)	6,800 (30.6)
	4 (101.6)	5,700 (25.7)	6,540 (29.4)	8,160 (36.7)	6,800 (30.6)	9,200 (41.4)	6,800 (30.6)
	6 (152.4)	7,910 (35.6)	7,025 (31.6)	9,550 (43.0)	7,190 (32.4)	10,730 (48.3)	7,190 (32.4)
5/8 (15.9)	2 3/4 (69.9)	6,240 (27.8)	9,280 (41.8)	8,300 (37.4)	11,900 (53.6)	9,860 (44.4)	11,900 (53.6)
	4 (101.6)	9,600 (43.2)	9,280 (41.8)	10,825 (48.7)	11,900 (53.6)	13,495 (60.7)	11,900 (53.6)
	5 (127.0)	10,640 (47.3)	9,280 (41.8)	12,510 (56.3)	11,900 (53.6)	16,410 (73.8)	11,900 (53.6)
	7 (177.8)	12,500 (55.6)	9,760 (43.9)	15,880 (71.5)	12,170 (54.8)	16,410 (73.8)	12,170 (54.8)
3/4 (19.1)	3 3/8 (85.7)	7,420 (33.0)	12,380 (55.7)	9,500 (42.3)	15,060 (67.8)	12,540 (56.4)	15,060 (67.8)
	5 (127.0)	10,640 (47.3)	12,380 (55.7)	14,630 (65.8)	15,060 (67.8)	17,265 (77.7)	15,060 (67.8)
	6 (152.4)	10,640 (47.3)	12,380 (55.7)	17,080 (76.9)	15,060 (67.8)	20,180 (90.8)	15,060 (67.8)
	8 (203.2)	14,000 (62.3)	13,600 (61.2)	22,000 (99.0)	17,110 (77.0)	24,905 (112.1)	17,110 (77.0)
7/8 (22.2)	3 7/8 (98.4)	7,600 (34.2)	17,960 (80.8)	12,300 (55.4)	24,160 (108.7)	17,300 (77.9)	24,160 (108.7)
	4 1/2 (114.3)	9,600 (43.2)	17,960 (80.8)	15,620 (70.3)	24,160 (108.7)	20,075 (90.3)	24,160 (108.7)
	5 3/4 (146.1)	10,640 (47.3)	17,960 (80.8)	19,880 (89.5)	24,160 (108.7)	25,625 (115.3)	24,160 (108.7)
	7 (177.8)	12,680 (56.4)	17,960 (80.8)	20,440 (92.0)	24,160 (108.7)	31,180 (140.3)	24,160 (108.7)
	8 (203.2)	15,160 (67.4)	18,630 (83.8)	22,840 (101.6)	25,710 (115.7)	31,180 (140.3)	25,710 (115.7)
1 (25.4)	4 1/2 (114.3)	8,740 (39.3)	26,420 (118.9)	13,820 (62.2)	31,100 (140.0)	21,220 (94.4)	31,100 (140.0)
	5 1/2 (139.7)	12,770 (57.5)	26,420 (118.9)	20,280 (91.3)	31,100 (140.0)	27,800 (123.7)	31,100 (140.0)
	6 1/2 (165.1)	16,605 (74.7)	26,420 (118.9)	25,485 (114.7)	31,100 (140.0)	34,360 (152.8)	31,100 (140.0)
	8 (203.2)	22,360 (100.6)	26,420 (118.9)	27,040 (121.7)	31,100 (140.0)	44,220 (199.0)	31,100 (140.0)
	9 (228.6)	26,195 (117.9)	27,020 (121.6)	34,205 (153.9)	32,370 (145.7)	44,220 (199.0)	32,370 (145.7)
1 1/4 (31.8)	5 1/2 (139.7)	16,800 (75.6)	40,820 (183.7)	26,980 (121.4)	40,820 (183.7)	36,925 (166.2)	40,820 (183.7)
	7 (177.8)	25,360 (114.1)	40,820 (183.7)	35,410 (159.3)	40,820 (183.7)	44,845 (201.8)	40,820 (183.7)
	10 (254.0)	28,800 (129.6)	40,820 (183.7)	52,280 (235.3)	40,820 (183.7)	60,690 (273.1)	40,820 (183.7)

1. The values listed above are ultimate load capacities which should be reduced by a minimum safety factor of 4.0 or greater to determine the allowable working load. Consideration of safety factors of 10 or higher may be necessary depending on the application, such as life safety or overhead.
 2. Linear interpolation may be used to determine ultimate loads for intermediate embedments and compressive strengths.

PERFORMANCE DATA

Allowable Load Capacities for Carbon Steel Power-Stud in Normal-Weight Concrete^{1,2}

Anchor Diameter <i>d</i> in. (mm)	Minimum Embedment Depth <i>h_v</i> in. (mm)	Minimum Concrete Compressive Strength (<i>f'_c</i>)					
		2,000 psi (13.8 MPa)		4,000 psi (27.6 MPa)		6,000 psi (41.4 MPa)	
		Tension lbs. (kN)	Shear lbs. (kN)	Tension lbs. (kN)	Shear lbs. (kN)	Tension lbs. (kN)	Shear lbs. (kN)
1/4 (6.4)	1 1/8 (28.6)	310 (1.4)	395 (1.8)	360 (1.6)	405 (1.8)	435 (2.0)	405 (1.8)
	1 1/2 (38.1)	410 (1.8)	395 (1.8)	520 (2.3)	405 (1.8)	525 (2.4)	405 (1.8)
	2 (50.8)	475 (2.1)	395 (1.8)	520 (2.3)	405 (1.8)	525 (2.4)	405 (1.8)
	2 3/4 (69.9)	585 (2.6)	415 (1.9)	590 (2.7)	520 (2.3)	635 (2.9)	520 (2.3)
3/8 (9.5)	1 5/8 (41.3)	480 (2.2)	890 (4.0)	760 (3.4)	940 (4.2)	760 (3.4)	940 (4.2)
	2 (50.8)	700 (3.2)	890 (4.0)	965 (4.3)	940 (4.2)	1,020 (4.6)	940 (4.2)
	3 (76.2)	1,025 (4.6)	890 (4.0)	1,505 (6.8)	940 (4.2)	1,505 (6.8)	940 (4.2)
	4 1/4 (108.0)	1,260 (5.7)	960 (4.3)	1,505 (6.8)	1,295 (5.8)	1,505 (6.8)	1,295 (5.8)
1/2 (12.7)	2 1/4 (57.2)	860 (3.9)	1,635 (7.4)	1,390 (6.3)	1,700 (7.7)	1,635 (7.4)	1,700 (7.7)
	3 (76.2)	1,275 (5.7)	1,635 (7.4)	2,040 (9.2)	1,700 (7.7)	2,300 (10.4)	1,700 (7.7)
	4 (101.6)	1,425 (6.4)	1,635 (7.4)	2,040 (9.2)	1,700 (7.7)	2,300 (10.4)	1,700 (7.7)
	6 (152.4)	1,980 (8.9)	1,755 (7.9)	2,390 (10.8)	1,800 (8.1)	2,685 (12.1)	1,800 (8.1)
5/8 (15.9)	2 3/4 (69.9)	1,560 (6.9)	2,320 (10.4)	2,075 (9.3)	2,975 (13.4)	2,465 (11.1)	2,975 (13.4)
	4 (101.6)	2,400 (10.8)	2,320 (10.4)	2,705 (12.2)	2,975 (13.4)	3,375 (15.2)	2,975 (13.4)
	5 (127.0)	2,660 (11.8)	2,320 (10.4)	3,130 (14.1)	2,975 (13.4)	4,105 (18.5)	2,975 (13.4)
	7 (177.8)	3,125 (13.9)	2,440 (11.0)	3,970 (17.9)	3,045 (13.7)	4,105 (18.5)	3,045 (13.7)
3/4 (19.1)	3 3/8 (85.7)	1,855 (8.3)	3,095 (13.9)	2,375 (10.6)	3,765 (16.9)	3,135 (14.1)	3,765 (16.9)
	5 (127.0)	2,660 (11.8)	3,095 (13.9)	3,660 (16.5)	3,765 (16.9)	4,315 (19.4)	3,765 (16.9)
	6 (152.4)	2,660 (11.8)	3,095 (13.9)	4,270 (19.2)	3,765 (16.9)	5,045 (22.7)	3,765 (16.9)
	8 (203.2)	3,500 (15.6)	3,400 (15.3)	5,710 (25.4)	4,280 (19.3)	6,225 (28.0)	4,280 (19.3)
7/8 (22.2)	3 7/8 (98.4)	1,900 (8.6)	4,490 (20.2)	3,075 (13.8)	6,040 (27.2)	4,325 (19.5)	6,040 (27.2)
	4 1/2 (114.3)	2,400 (10.8)	4,490 (20.2)	3,905 (17.6)	6,040 (27.2)	5,305 (23.6)	6,040 (27.2)
	5 3/4 (146.1)	2,660 (11.8)	4,490 (20.2)	4,970 (22.4)	6,040 (27.2)	6,950 (30.9)	6,040 (27.2)
	7 (177.8)	3,170 (14.1)	4,490 (20.2)	5,110 (23.0)	6,040 (27.2)	8,590 (38.2)	6,040 (27.2)
	8 (203.2)	3,790 (16.9)	4,660 (21.0)	5,710 (25.4)	6,430 (28.9)	7,795 (35.1)	6,430 (28.9)
1 (25.4)	4 1/2 (114.3)	2,185 (9.8)	6,605 (29.7)	3,455 (15.5)	7,775 (35.0)	5,305 (23.6)	7,775 (35.0)
	5 1/2 (139.7)	3,195 (14.4)	6,605 (29.7)	5,070 (22.8)	7,775 (35.0)	6,950 (30.9)	7,775 (35.0)
	6 1/2 (165.1)	4,150 (18.7)	6,605 (29.7)	6,370 (28.7)	7,775 (35.0)	8,590 (38.2)	7,775 (35.0)
	8 (203.2)	5,590 (25.2)	6,605 (29.7)	6,760 (30.4)	7,775 (35.0)	11,055 (49.7)	7,775 (35.0)
	9 (228.6)	6,550 (29.5)	6,755 (30.4)	8,550 (38.5)	8,095 (36.4)	11,055 (49.7)	8,095 (36.4)
1 1/4 (31.8)	5 1/2 (139.7)	4,200 (18.9)	10,205 (45.9)	6,745 (30.4)	10,205 (45.9)	9,230 (41.5)	10,205 (45.9)
	7 (177.8)	6,340 (28.5)	10,205 (45.9)	8,855 (39.8)	10,205 (45.9)	11,210 (50.4)	10,205 (45.9)
	10 (254.0)	7,200 (32.4)	10,205 (45.9)	13,070 (58.8)	10,205 (45.9)	15,175 (68.3)	10,205 (45.9)

1. Allowable load capacities listed are calculated using an applied safety factor of 4.0. Consideration of safety factors of 10 or higher may be necessary depending on the application, such as life safety or overhead.

2. Linear interpolation may be used to determine allowable loads for intermediate embedments and compressive strengths.

MECHANICAL ANCHORS

PERFORMANCE DATA

Ultimate and Allowable Load Capacities for Carbon Steel Power-Stud in Structural Lightweight Concrete^{1,2,3}

Anchor Diameter <i>d</i> in. (mm)	Install Torque <i>T_{inst}</i> ft.-lbs.	Min. Embed. Depth <i>h_v</i> in. (mm)	Minimum Concrete Compressive Strength (<i>f'_c</i>)						Shear, lbs (kN)	
			Tension, lbs (kN)						<i>f'_c</i> ≥ 3,000 psi (20.7 MPa)	
			3,000 psi (20.7 MPa)		4,000 psi (27.6 MPa)		5,000 psi (34.5 MPa)			
			Ultimate Load	Allowable Load	Ultimate Load	Allowable Load	Ultimate Load	Allowable Load	Ultimate Load	Allowable Load
1/4 (6.4)	4	1 1/8 (28.6)	720 (3.2)	180 (0.8)	960 (4.3)	240 (1.1)	1,200 (5.4)	300 (1.4)	720 (3.2)	180 (0.8)
3/8 (9.5)	20	1 5/8 (41.3)	1,600 (7.2)	400 (1.8)	1,940 (8.7)	485 (2.2)	2,300 (10.4)	575 (2.6)	1,840 (8.3)	460 (2.1)
		3 (76.2)	–	–	2,860 (12.9)	715 (3.2)	–	–	1,840 (8.3)	460 (2.1)
1/2 (12.7)	30	2 1/4 (57.2)	2,820 (12.7)	705 (3.2)	3,180 (14.3)	795 (3.6)	3,560 (16.0)	890 (4.0)	5,040 (22.7)	1,260 (5.7)
		3 (76.2)	–	–	4,020 (18.1)	1,005 (4.5)	–	–	5,040 (22.7)	1,260 (5.7)
		5 (127.0)	–	–	4,200 (18.9)	1,050 (4.7)	–	–	5,040 (22.7)	1,260 (5.7)
5/8 (15.9)	65	2 3/4 (69.9)	4,380 (19.7)	1,095 (4.9)	4,980 (22.4)	1,245 (5.6)	5,580 (25.1)	1,395 (6.3)	6,940 (31.2)	1,735 (7.8)
		3 1/2 (88.9)	–	–	4,840 (21.8)	1,210 (5.4)	–	–	6,940 (31.2)	1,735 (7.8)
		5 (127.0)	–	–	6,920 (31.1)	1,730 (7.8)	–	–	6,940 (31.2)	1,735 (7.8)
3/4 (19.1)	90	3 3/8 (85.7)	5,060 (22.8)	1,265 (5.7)	5,600 (25.2)	1,400 (6.3)	6,140 (27.6)	1,535 (6.9)	9,880 (44.5)	2,470 (11.1)
		4 (101.6)	–	–	8,240 (37.1)	2,060 (9.3)	–	–	9,880 (44.5)	2,470 (11.1)
		5 (127.0)	–	–	9,300 (41.9)	2,325 (10.5)	–	–	9,880 (44.5)	2,470 (11.1)

1. The values listed above are ultimate and allowable load capacities for anchors installed in sand-lightweight concrete.
2. Allowable loads capacities are calculated using an applied safety factor of 4.0. Consideration of safety factors of 10 or higher may be necessary depending on the application, such as life safety or overhead.
3. Linear interpolation may be used to determine ultimate loads for intermediate embedments and compressive strengths.

PERFORMANCE DATA

Ultimate and Allowable Load Capacities for Carbon Steel Power-Stud Installed Through Metal Deck into Structural Lightweight Concrete^{1,2,3,4}

Anchor Diameter <i>d</i> in. (mm)	Install Torque <i>T_{inst}</i> ft.-lbs.	Min. Embed. Depth <i>h_v</i> in. (mm)	Lightweight Concrete over minimum 20 Gage Metal Deck, <i>f'_c</i> ≥ 3,000 (20.7 MPa)							
			Minimum 1-1/2" Wide Deck				Minimum 4-1/2" Wide Deck			
			Ultimate Load		Allowable Load		Ultimate Load		Allowable Load	
			Tension lbs. (kN)	Shear lbs. (kN)	Tension lbs. (kN)	Shear lbs. (kN)	Tension lbs. (kN)	Shear lbs. (kN)	Tension lbs. (kN)	Shear lbs. (kN)
1/4 (6.4)	4	1 1/8 (28.6)	880 (4.0)	1,840 (8.3)	220 (1.0)	460 (2.1)	880 (4.0)	1,840 (8.3)	220 (1.0)	460 (2.1)
3/8 (9.5)	20	1 5/8 (41.3)	880 (4.0)	2,800 (12.6)	220 (1.0)	700 (3.2)	1,520 (6.8)	2,800 (12.6)	380 (1.7)	700 (3.2)
		3 (76.2)	880 (4.0)	2,800 (12.6)	220 (1.0)	700 (3.2)	4,480 (20.2)	3,840 (17.3)	1,120 (5.0)	960 (4.3)
1/2 (12.7)	30	2 1/4 (57.2)	1,400 (6.3)	2,800 (12.6)	350 (1.6)	700 (3.2)	3,200 (14.4)	4,780 (21.5)	800 (3.6)	1,195 (5.4)
		3 (76.2)	1,400 (6.3)	2,800 (12.6)	350 (1.6)	700 (3.2)	4,560 (20.5)	5,960 (26.8)	1,140 (5.1)	1,490 (6.7)
		4 (101.6)	1,400 (6.3)	2,800 (12.6)	350 (1.6)	700 (3.2)	6,360 (28.6)	7,540 (33.9)	1,590 (7.2)	1,885 (8.5)
5/8 (15.9)	65	2 3/4 (69.9)	-	-	-	-	3,200 (14.4)	4,780 (21.5)	800 (3.6)	1,195 (5.4)
		3 1/2 (88.9)	-	-	-	-	5,540 (24.9)	7,160 (32.2)	1,385 (6.2)	1,790 (8.1)
		5 (127.0)	-	-	-	-	9,200 (41.4)	10,940 (49.2)	2,300 (10.4)	2,735 (12.3)
3/4 (19.1)	90	3 3/8 (85.7)	-	-	-	-	2,740 (12.3)	7,000 (31.5)	685 (3.1)	1,750 (7.9)
		5 (127.0)	-	-	-	-	10,840 (48.8)	12,570 (56.6)	2,710 (12.2)	3,140 (14.1)

MECHANICAL ANCHORS

- The values listed above are ultimate and allowable load capacities for anchors installed in sand-lightweight concrete.
- Allowable loads capacities are calculated using an applied safety factor of 4.0. Consideration of safety factors of 10 or higher may be necessary depending on the application, such as life safety or overhead.
- Tabulated load values are for anchors installed in the center of the flute. Spacing distances shall be in accordance with the spacing table for lightweight concrete listed in the Design Criteria section. Linear interpolation may be used for flute edge distances between those listed. Flute edge distance equals one-half the minimum deck width.
- Anchors are permitted to be installed in the lower or upper flute of the metal deck provided the proper installation procedures are maintained.

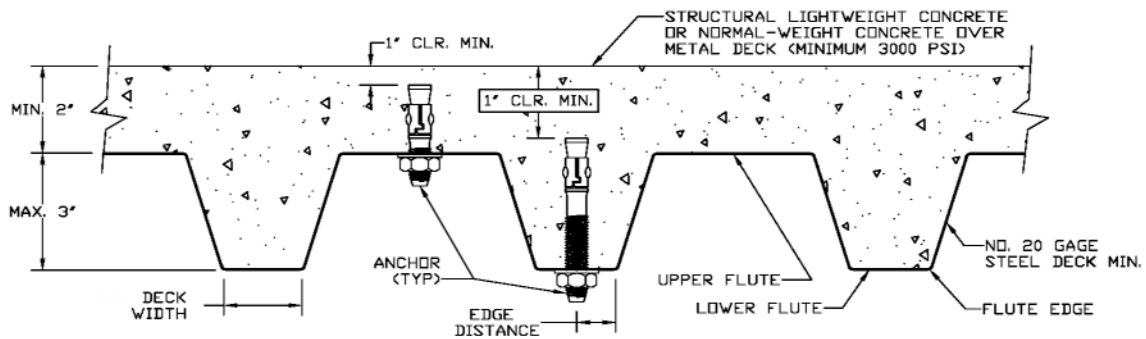

PERFORMANCE DATA

Ultimate and Allowable Load Capacities for Carbon Steel Power-Stud in Grout-Filled Concrete Masonry^{1,2,3}

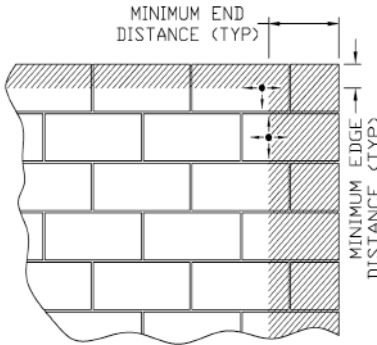

Anchor Dia. <i>d</i> in. (mm)	Install Torque <i>T_{inst}</i> ft.-lbs.	Min. Embed. Depth <i>h_v</i> in. (mm)	Min. Edge Distance in. (mm)	Min. End Distance in. (mm)	Grout-Filled Concrete Masonry <i>f'_m</i> ≥ 1,500 psi (10.4 MPa)			
					Ultimate Load		Allowable Load	
					Tension lbs. (kN)	Shear lbs. (kN)	Tension lbs. (kN)	Shear lbs. (kN)
1/4 (6.4)	4	1 1/8 (28.6)	3 3/4 (95.3)	3 3/4 (95.3)	1,230 (5.5)	1,230 (5.5)	245 (1.1)	245 (1.1)
		2 (50.8)	5 1/4 (133.4)	3 3/4 (95.3)	1,670 (7.5)	1,230 (5.5)	335 (1.5)	245 (1.1)
3/8 (9.5)	20	1 5/8 (41.3)	5 5/8 (142.9)	5 5/8 (142.9)	1,990 (9.0)	3,240 (14.6)	400 (1.8)	650 (2.9)
		3 (76.2)	7 7/8 (200.0)	5 5/8 (142.9)	2,200 (9.9)	3,240 (14.6)	440 (2.0)	650 (2.9)
1/2 (12.7)	30	2 1/4 (57.2)	7 1/2 (190.5)	7 1/2 (190.5)	2,260 (10.2)	6,230 (28.0)	450 (2.0)	1,245 (5.6)
		4 (101.6)	10 1/2 (266.7)	7 1/2 (190.5)	2,620 (11.8)	6,230 (28.0)	525 (2.4)	1,245 (5.6)
5/8 (15.9)	65	2 3/4 (69.9)	9 3/8 (238.1)	9 3/8 (238.1)	3,170 (14.3)	7,830 (35.2)	635 (2.9)	1,565 (7.0)
		5 (127.0)	13 1/8 (333.4)	9 3/8 (238.1)	3,780 (17.0)	7,830 (35.2)	755 (3.4)	1,565 (7.0)
3/4 (19.1)	90	3 3/8 (85.7)	11 1/4 (285.8)	11 1/4 (285.8)	4,085 (18.4)	9,760 (43.9)	815 (3.7)	1,950 (8.8)
		5 (127.0)	15 3/4 (400.1)	11 1/4 (285.8)	4,420 (19.9)	9,760 (43.9)	885 (4.0)	1,950 (8.8)

1. Tabulated load values are for anchors installed in minimum 6-inch wide, Grade N, Type II, medium and normal-weight concrete masonry units conforming to ASTM C 90 that have reached the minimum designated ultimate compressive strength at the time of installation (*f'_m* ≥ 1,500 psi).
2. Allowable load capacities listed are calculated using an applied safety factor of 5.0. Consideration of safety factors of 10 or higher may be necessary depending on the application, such as life safety or overhead.
3. The tabulated values are for anchors installed at a minimum of 12 anchor diameters on center for 100 percent capacity. Spacing distances may be reduced to 6 anchor diameters on center provided the capacities are reduced by 50 percent. Linear interpolation may be used for intermediate spacing.

DESIGN CRITERIA (ALLOWABLE STRESS DESIGN)

Combined Loading

For anchors loaded in both shear and tension, the combination of loads should be proportioned as follows:

$$\left(\frac{N_u}{N_n}\right)^{\frac{5}{3}} + \left(\frac{V_u}{V_n}\right)^{\frac{5}{3}} \leq 1 \quad \text{OR} \quad \left(\frac{N_u}{N_n}\right) + \left(\frac{V_u}{V_n}\right) \leq 1$$

Where: *N_u* = Applied Service Tension Load
N_n = Allowable Tension Load
V_u = Applied Service Shear Load
V_n = Allowable Shear Load

Load Adjustment Factors for Spacing and Edge Distances

Anchor Installed in Normal-Weight Concrete					
Anchor Dimension	Load Type	Critical Distance (Full Anchor Capacity)	Critical Load Factor	Minimum Distance (Reduced Capacity)	Minimum Load Factor
Spacing (<i>s</i>)	Tension and Shear	<i>s_{cr}</i> = 2.0 <i>h_v</i>	<i>F_{N_S}</i> = <i>F_{V_S}</i> = 1.0	<i>s_{min}</i> = <i>h_v</i>	<i>F_{N_S}</i> = <i>F_{V_C}</i> = 50
Edge Distance (<i>c</i>)	Tension	<i>c_{cr}</i> = 12 <i>d</i>	<i>F_{N_C}</i> = 1.0	<i>c_{min}</i> = 5 <i>d</i>	<i>F_{N_C}</i> = .75
	Shear	<i>c_{cr}</i> = 12 <i>d</i>	<i>F_{V_C}</i> = 1.0	<i>c_{min}</i> = 5 <i>d</i>	<i>F_{V_C}</i> = .75

Anchor Installed in Lightweight Concrete					
Anchor Dimension	Load Type	Critical Distance (Full Anchor Capacity)	Critical Load Factor	Minimum Distance (Reduced Capacity)	Minimum Load Factor
Spacing (<i>s</i>)	Tension and Shear	<i>s_{cr}</i> = 2.0 <i>h_v</i>	<i>F_{N_S}</i> = <i>F_{V_S}</i> = 1.0	<i>s_{min}</i> = <i>h_v</i>	<i>F_{N_S}</i> = <i>F_{V_C}</i> = 0.50
Edge Distance (<i>c</i>)	Tension	<i>c_{cr}</i> = 12 <i>d</i>	<i>F_{N_C}</i> = 1.0	<i>c_{min}</i> = 5 <i>d</i>	<i>F_{N_C}</i> = 0.95
	Shear	<i>c_{cr}</i> = 12 <i>d</i>	<i>F_{V_C}</i> = 1.0	<i>c_{min}</i> = 5 <i>d</i>	<i>F_{V_C}</i> = 0.30

(d1)

DESIGN CRITERIA (ALLOWABLE STRESS DESIGN)

Spacing Load Adjustment Factors for Normal-Weight and Lightweight Concrete (Continued Below)

Spacing, Tension (F_{N_s}) & Shear (F_{V_s})																			
Dia. (in.)	1/4				3/8				1/2					5/8					
h_v (in.)	1 1/8	1 1/2	2	2 3/4	1 5/8	2	3	4 1/4	2 1/4	3	4	5	6	2 3/4	3 1/2	4	5	7	
s_{cr} (in.)	2 1/4	3	4	5 1/2	3 1/4	4	6	8 1/2	4 1/2	6	8	10	12	5 1/2	7	8	10	14	
s_{min} (in.)	1 1/8	1 1/2	2	2 3/4	1 5/8	2	3	4 1/4	2 1/4	3	4	5	6	2 3/4	3 1/2	4	5	7	
Spacing, s (inches)	1 1/8	0.50																	
	1 1/2	0.67	0.50																
	1 5/8	0.72	0.54			0.50													
	2	0.89	0.67	0.50		0.62	0.50												
	2 1/4	1.00	0.75	0.56		0.69	0.56			0.50									
	2 3/4		0.92	0.69	0.50	0.85	0.69			0.61				0.50					
	3		1.00	0.75	0.55	0.92	0.75	0.50		0.67	0.50				0.55				
	3 1/4			0.81	0.59	1.00	0.81	0.54		0.72	0.54				0.59				
	3 1/2			0.88	0.64		0.88	0.58		0.78	0.58				0.64	0.50			
	4			1.00	0.73		1.00	0.67		0.89	0.67	0.50			0.73	0.57	0.50		
	4 1/4				0.77			0.71	0.50	0.94	0.71	0.53			0.77	0.61	0.53		
	4 1/2				0.82			0.75	0.53	1.00	0.75	0.56			0.82	0.64	0.56		
	5				0.91			0.83	0.59		0.83	0.63	0.50		0.91	0.71	0.63	0.50	
	5 1/2				1.00			0.92	0.65		0.92	0.69	0.55		1.00	0.79	0.69	0.55	
	6							1.00	0.71		1.00	0.75	0.60	0.50		0.86	0.75	0.60	
	7								0.82			0.88	0.70	0.58		1.00	0.88	0.70	0.50
	8								0.94			1.00	0.80	0.67			1.00	0.80	0.57
8 1/2								1.00				0.85	0.71				0.85	0.61	
10												1.00	0.83				1.00	0.71	
11													0.92					0.79	
12													1.00					0.86	
13																		0.93	
14																		1.00	

Spacing Load Adjustment Factors for Normal-Weight and Lightweight Concrete (Continued from Above)

Spacing, Tension (F_{N_s}) & Shear (F_{V_s})																			
Dia. (in.)	3/4					7/8					1					1 1/4			
h_v (in.)	3 3/8	4	5	6	8	3 7/8	4 1/2	5 3/4	7	8	4 1/2	5 1/2	6 1/2	8	9	5 1/2	7	10	
s_{cr} (in.)	6 3/4	8	10	12	16	7 3/4	9	11 1/2	14	16	9	11	13	16	18	11	14	20	
s_{min} (in.)	3 3/8	4	5	6	8	3 7/8	4 1/2	5 3/4	7	8	4 1/2	5 1/2	6 1/2	8	9	5 1/2	7	10	
Spacing, s (inches)	3 3/8	0.50																	
	3 7/8	0.57				0.50													
	4	0.59	0.50			0.52													
	4 1/2	0.67	0.56			0.58	0.50				0.50								
	5	0.74	0.63	0.50		0.65	0.56				0.56								
	5 1/2	0.81	0.69	0.55		0.71	0.61				0.61	0.50				0.50			
	5 3/4	0.85	0.72	0.58		0.74	0.64	0.50			0.64	0.52				0.52			
	6	0.89	0.75	0.60	0.50	0.77	0.67	0.52			0.67	0.55				0.55			
	6 1/2	0.96	0.81	0.65	0.54	0.84	0.72	0.57			0.72	0.59	0.50			0.59			
	6 3/4	1.00	0.84	0.68	0.56	0.87	0.75	0.59			0.75	0.61	0.52			0.61			
	7		0.88	0.70	0.58	0.90	0.78	0.61	0.50		0.78	0.64	0.54			0.64	0.50		
	7 3/4		0.97	0.78	0.65	1.00	0.86	0.67	0.55		0.86	0.70	0.60			0.70	0.55		
	8		1.00	0.80	0.67	0.50	0.89	0.70	0.57	0.50	0.89	0.73	0.62	0.50		0.73	0.57		
	9			0.90	0.75	0.56	1.00	0.78	0.64	0.56	1.00	0.82	0.69	0.56	0.50	0.82	0.64		
	10			1.00	0.83	0.63		0.87	0.71	0.63		0.91	0.77	0.63	0.56	0.91	0.71	0.50	
	11				0.92	0.69		0.96	0.79	0.69		1.00	0.85	0.69	0.61	1.00	0.79	0.55	
	11 1/2				0.96	0.72		1.00	0.82	0.72			0.88	0.72	0.64		0.82	0.58	
12				1.00	0.75			0.86	0.75			0.92	0.75	0.67		0.86	0.60		
13					0.81			0.93	0.81			1.00	0.81	0.72		0.93	0.65		
14					0.88			1.00	0.88				0.88	0.78		1.00	0.70		
16					1.00				1.00					1.00	0.89		0.80		
18															1.00		0.90		
20																	1.00		

Notes: Critical spacing (s_{cr}) is equal to 2 embedment depths ($2h_v$) at which the anchor achieves 100% of load.

Minimum spacing (s_{min}) is equal to 1 embedment depth (h_v) at which the anchor achieves 50% of load.

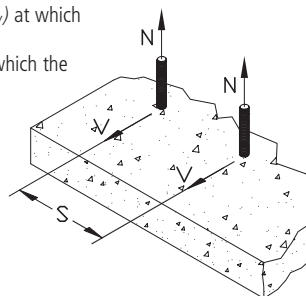

DESIGN CRITERIA (ALLOWABLE STRESS DESIGN)

Edge Distance Load Adjustment Factors for Normal-Weight Concrete

Edge Distance, Tension (F_{Nc})								
Diameter (in.)	1/4	3/8	1/2	5/8	3/4	7/8	1	
C_{cr} (in.)	3	4 1/2	6	7 1/2	9	10 1/2	12	
C_{min} (in.)	1 1/4	1 7/8	2 1/2	3 1/8	3 3/4	4 3/8	5	
Edge Distance, c (inches)	1 1/4	0.75						
	1 5/8	0.80						
	1 7/8	0.84	0.75					
	2	0.86	0.76					
	2 1/2	0.93	0.81	0.75				
	3	1.00	0.86	0.79				
	3 1/8		0.87	0.79	0.75			
	3 3/4		0.93	0.84	0.79	0.75		
	4		0.95	0.86	0.80	0.76		
	4 3/8		0.99	0.88	0.82	0.78	0.75	
	4 1/2		1.00	0.89	0.83	0.79	0.76	
	5			0.93	0.86	0.81	0.78	0.75
	6			1.00	0.91	0.86	0.82	0.79
	6 1/4				0.93	0.87	0.83	0.79
	7				0.97	0.90	0.86	0.82
	7 1/2				1.00	0.93	0.88	0.84
8					0.95	0.90	0.86	
9					1.00	0.94	0.89	
10 1/2						1.00	0.95	
12							1.00	
15								

Notes: For anchors loaded in tension, the critical edge distance (c_{cr}) is equal to 12 anchor diameters ($12d$) at which the anchor achieves 100% of load. Minimum edge distance (c_{min}) is equal to 5 anchor diameters ($5d$) at which the anchor achieves 75% of load.

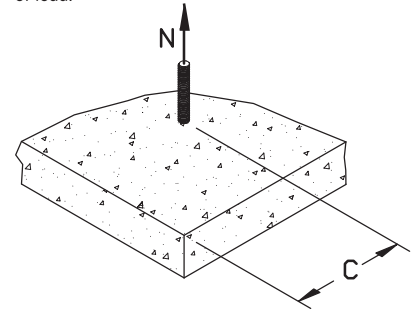

Edge Distance, Shear (F_{Vc})								
Diameter (in.)	1/4	3/8	1/2	5/8	3/4	7/8	1	
C_{cr} (in.)	3	4 1/2	6	7 1/2	9	10 1/2	12	
C_{min} (in.)	1 1/4	1 7/8	2 1/2	3 1/8	3 3/4	4 3/8	5	
Edge Distance, c (inches)	1 1/4	0.35						
	1 5/8	0.49						
	1 7/8	0.58	0.35					
	2	0.63	0.38					
	2 1/2	0.81	0.50	0.35				
	3	1.00	0.63	0.44				
	3 1/8		0.66	0.47	0.35			
	3 3/4		0.81	0.58	0.44	0.35		
	4		0.88	0.63	0.48	0.38		
	4 3/8		0.97	0.70	0.54	0.43	0.35	
	4 1/2		1.00	0.72	0.55	0.44	0.36	
	5			0.81	0.63	0.50	0.42	0.35
	6			1.00	0.78	0.63	0.52	0.44
	6 1/4				0.81	0.66	0.55	0.47
	7				0.93	0.75	0.63	0.54
	7 1/2				1.00	0.81	0.68	0.58
8					0.88	0.73	0.63	
9					1.00	0.84	0.72	
10 1/2						1.00	0.86	
12							1.00	
15								

Notes: For anchors loaded in shear, the critical edge distance (c_{cr}) is equal to 12 anchor diameters ($12d$) at which the anchor achieves 100% of load.

Minimum edge distance (c_{min}) is equal to 5 anchor diameters ($5d$) at which the anchor achieves 35% of load.

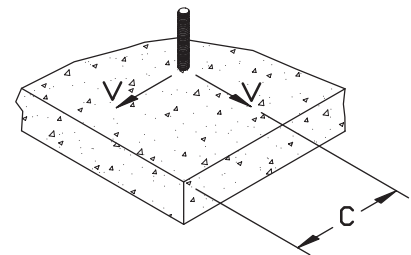

DESIGN CRITERIA (ALLOWABLE STRESS DESIGN)

Edge Distance Load Adjustment Factors for Lightweight Concrete

Edge Distance, Tension (F_{Nc})								
Diameter (in.)	1/4	3/8	1/2	5/8	3/4	7/8	1	
C_{cr} (in.)	3	4 1/2	6	7 1/2	9	10 1/2	12	
C_{min} (in.)	1 1/4	1 7/8	2 1/2	3 1/8	3 3/4	4 3/8	5	
Edge Distance, c (inches)	1 1/4	0.95						
	1 5/8	0.96						
	1 7/8	0.97	0.95					
	2	0.97	0.95					
	2 1/2	0.99	0.96	0.95				
	3	1.00	0.97	0.96				
	3 1/8		0.97	0.96	0.95			
	3 3/4		0.99	0.97	0.96	0.95		
	4		0.99	0.97	0.96	0.95		
	4 3/8		1.00	0.98	0.96	0.96	0.95	
	4 1/2		1.00	0.98	0.97	0.96	0.95	
	5			0.99	0.97	0.96	0.96	0.95
	6			1.00	0.98	0.97	0.96	0.96
	6 1/4				0.99	0.97	0.97	0.96
	7				0.99	0.98	0.97	0.96
7 1/2				1.00	0.99	0.98	0.97	
8					0.99	0.98	0.97	
9					1.00	0.99	0.98	
10 1/2						1.00	0.99	
12							1.00	
15								

Notes: For anchors loaded in tension, the critical edge distance (C_{cr}) is equal to 12 anchor diameters ($12d$) at which the anchor achieves 100% of load. Minimum edge distance (C_{min}) is equal to 5 anchor diameters ($5d$) at which the anchor achieves 95% of load.

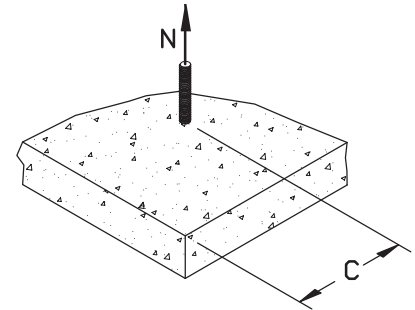

Edge Distance, Shear (F_{Vc})								
Diameter (in.)	1/4	3/8	1/2	5/8	3/4	7/8	1	
C_{cr} (in.)	3	4 1/2	6	7 1/2	9	10 1/2	12	
C_{min} (in.)	1 1/4	1 7/8	2 1/2	3 1/8	3 3/4	4 3/8	5	
Edge Distance, c (inches)	1 1/4	0.30						
	1 5/8	0.45						
	1 7/8	0.55	0.30					
	2	0.60	0.33					
	2 1/2	0.80	0.47	0.30				
	3	1.00	0.60	0.40				
	3 1/8		0.63	0.43	0.30			
	3 3/4		0.80	0.55	0.40	0.30		
	4		0.87	0.60	0.44	0.33		
	4 3/8		0.97	0.68	0.50	0.38	0.30	
	4 1/2		1.00	0.70	0.52	0.40	0.31	
	5			0.80	0.60	0.47	0.37	0.30
	6			1.00	0.76	0.60	0.49	0.40
	6 1/4				0.80	0.63	0.51	0.43
	7				0.92	0.73	0.60	0.50
7 1/2				1.00	0.80	0.66	0.55	
8					0.87	0.71	0.60	
9					1.00	0.83	0.70	
10 1/2						1.00	0.85	
12							1.00	
15								

Notes: For anchors loaded in shear, the critical edge distance (C_{cr}) is equal to 12 anchor diameters ($12d$) at which the anchor achieves 100% of load.

Minimum edge distance (C_{min}) is equal to 5 anchor diameters ($5d$) at which the anchor achieves 30% of load.

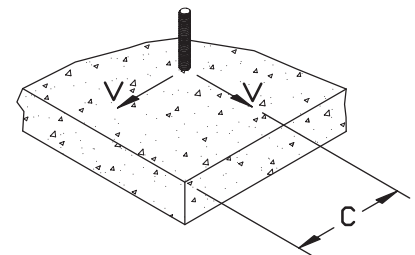

ORDERING INFORMATION

Carbon Steel Power-Stud

Cat. No.	Anchor Size	Min. Embed.	Thread Length	Std. Box	Std. Carton	Wt./100	FM or UL
7400	1/4" x 1 3/4"	1 1/8"	3/4"	100	500	3	-
7402	1/4" x 2 1/4"	1 1/8"	1 1/4"	100	500	3 1/2	-
7404	1/4" x 3 1/4"	1 1/8"	2 1/4"	100	500	4 3/4	-
7410	3/8" x 2 1/4"	1 5/8"	1 1/4"	50	250	8 3/4	FM/UL
7412	3/8" x 2 3/4"	1 5/8"	1 5/8"	50	250	9 1/2	FM/UL
7413	3/8" x 3"	1 5/8"	1 7/8"	50	250	10 3/4	FM/UL
7414	3/8" x 3 1/2"	1 5/8"	2 3/8"	50	250	12	FM/UL
7415	3/8" x 3 3/4"	1 5/8"	2 5/8"	50	250	12 3/4	FM/UL
7416	3/8" x 5"	1 5/8"	3 7/8"	50	250	15 1/2	FM/UL
7417	3/8" x 7"	1 5/8"	5 7/8"	50	200	21	FM/UL
7420	1/2" x 2 3/4"	2 1/4"	1 3/8"	50	200	18	FM/UL
7422	1/2" x 3 3/4"	2 1/4"	2 3/8"	50	200	23	FM/UL
7423	1/2" x 4 1/2"	2 1/4"	3 1/8"	50	200	28	FM/UL
7424	1/2" x 5 1/2"	2 1/4"	4 1/8"	50	150	32	FM/UL
7426	1/2" x 7"	2 1/4"	5 5/8"	25	100	44	FM/UL
7427	1/2" x 8 1/2"	2 1/4"	7 1/8"	25	100	46	FM/UL
7430	5/8" x 3 1/2"	2 3/4"	2"	25	100	40	FM/UL
7432	5/8" x 4 1/2"	2 3/4"	3"	25	100	54	FM/UL
7433	5/8" x 5"	2 3/4"	3 1/2"	25	100	57	FM/UL
7434	5/8" x 6"	2 3/4"	4 1/2"	25	75	64	FM/UL
7436	5/8" x 7"	2 3/4"	5 1/2"	25	75	72	FM/UL
7438	5/8" x 8 1/2"	2 3/4"	7"	25	75	84	FM/UL
7439	5/8" x 10"	2 3/4"	8 1/2"	25	75	100	UL
7440	3/4" x 4 1/4"	3 3/8"	2 3/8"	20	60	70	UL
7441	3/4" x 4 3/4"	3 3/8"	2 7/8"	20	60	76	UL
7442	3/4" x 5 1/2"	3 3/8"	3 5/8"	20	60	85	UL
7444	3/4" x 6 1/4"	3 3/8"	4 3/8"	20	60	95	UL
7446	3/4" x 7"	3 3/8"	5 1/8"	20	60	105	UL
7448	3/4" x 8 1/2"	3 3/8"	6 5/8"	10	40	120	UL
7449	3/4" x 10"	3 3/8"	8 1/8"	10	30	135	UL
7451	3/4" x 12"	3 3/8"	10 1/8"	10	30	155	UL
7450	7/8" x 6"	3 7/8"	2 3/4"	10	40	120	UL
7452	7/8" x 8"	3 7/8"	4 3/4"	10	40	160	UL
7454	7/8" x 10"	3 7/8"	6 3/4"	10	30	200	UL
7461	1" x 6"	4 1/2"	2 3/8"	10	30	170	UL
7463	1" x 9"	4 1/2"	5 3/8"	10	30	240	-
7465	1" x 12"	4 1/2"	8 3/8"	5	15	300	-
7473	1 1/4" x 9"	5 1/2"	4 3/4"	5	15	360	-
7475	1 1/4" x 12"	5 1/2"	7 3/4"	5	15	480	-



The published length is the overall length of the anchor. Allow for fixture thickness plus one anchor diameter for the nut and washer thickness when selecting a length.

Rod Hanger Power-Stud

Cat. No.	Rod Size	Anchor Size	Drill Dia.	Min. Embed.	Thread Depth	Std. Box	Std. Ctn.	Wt./100	FM or UL
7806	3/8"	1/2" x 2 3/8"	1/2"	2 1/4"	9/16"	50	250	18	FM/UL



The published length is the overall length of the anchor.

Tie-Wire Power-Stud

Cat. No.	Size	Tie-Wire Hole Size	Min. Embed.	Std. Box	Std. Carton	Wt./100	FM or UL
7409	1/4" x 2"	9/32"	1 1/8"	100	500	3 3/4	FM/UL



The published length is the overall length of the anchor.

FM- Factory Mutual Approved
UL- Underwriters Laboratories Listed