



CAP SCREWS

NUCOR FASTENER

TECHNICAL DATA SHEET

Nucor Fastener is one of the largest manufacturers of Hex Head Cap Screws in the U.S.A. Cap Screws have been a serious business to us since we made our first cap screw back in 1986. Some manufacturers make cap screws when it's convenient, but, Nucor Fastener remains committed to the hex cap screw business. Nucor Fastener products are in assemblies across the U.S.A., from tricycles to tractor trailers. When Sourcing for your assembly needs, **Think Seriously** about **Nucor Fastener!**

Nucor Fastener Cap Screws are closely controlled to meet the dimensions of ASME (ANSI) B18.2.1. Cap Screws are proportioned and toleranced to assure full and proper loading when assembled into a tapped hole. Unlike a standard bolt, a washer face is provided under the head to provide a bearing surface when tightened. Also unlike a standard bolts, which have much looser tolerances and allow the body to be larger than the nominal diameter, Cap Screws have a body which is never larger than the nominal diameter to ensure fit-up into tapped holes without counterboring. The end of the Cap Screw is chamfered to aid in inserting into a tapped hole. Nucor Fastener Cap Screws are 100% Made in America from raw material melted and rolled in the U.S.A. They are cold formed on precision high speed formers, utilizing in-process quality systems, and have full traceability from raw material to each box shipped. Chemical and physical certifications are provided with every shipment, free of charge. Nucor Fastener has an A2LA Accredited laboratory and our Quality System is TS16949 and ISO9001 Registered.



SAE J429 GRADE IDENTIFICATION



SAE Grade 2



SAE Grade 5



SAE Grade 8

SAE vs. ASTM Specifications

With minor differences, SAE Grade Cap Screws have equivalent versions in ASTM standards. The Grade 2 Cap Screw is comparable to an ASTM A307 Grade A, the Grade 5 Cap Screw is the comparable to an ASTM A449 and the Grade 8 Cap Screw has the same strength as the ASTM A354 Grade BD. Our SAE Grade 8 and ASTM Grade BD Cap Screws are nearly identical, with the only exception being the ASTM required "BD" stamp on the head of the cap screw. Allowed steel chemistry is another difference, for example, SAE permits plain carbon 1541 grade steel for small diameter Grade 8 products, while ASTM A354 Grade BD requires alloy steel. Nucor Fastener only uses alloy steel for our Grade 8 Cap Screws. Required head mark differences are the primary reason that most grades can no longer be dual certified. Recently, the ASTM A449 standard changed to a required "A449" head mark from the SAE three radial lines head mark. Dimensions, mechanical properties and steel chemistry are still nearly identical, but, head marks aren't, ending the allowance for dual certification.

Mechanical Properties

The mechanical properties of finished Cap Screws are covered in the Society of Automotive Engineers (SAE) J429, "Mechanical and Material Requirements for Externally Threaded Fasteners Specification". This specification covers the materials, manufacturing methods, mechanical properties, and testing requirements for cap screws. Grade 2 (A307A) Cap Screws are low strength fasteners made from carbon steel, achieving their strength primarily from cold forming. Grade 5 (A449) Cap Screws are medium strength fasteners that achieve their strength from the medium carbon steel and a quench and temper heat treatment. Grade 8 Cap Screws (A354 GR BD) are high strength fasteners made from alloy steels that also achieve their strength from the alloy steel and a quench and temper heat treatment. Standard mechanical tests are performed in our A2LA (American Association for Laboratory Accreditation) Accredited Laboratory.

Table 1 – Mechanical Properties of SAE J429 Cap Screws

SAE GRADE	SIZE	PROOF STRESS (PSI)	TENSILE STRESS MIN. (PSI)	SURFACE HARDNESS HR30N MAX.	CORE HARDNESS ROCKWELL
2	1/4 - 3/4"	*	74,000	N/A	80 - 100**HRb
	Over 3/4"	*	60,000	N/A	70 - 100 HRb
5	1/4 - 1	85,000	120,000	54	25 - 34 HRC
	Over 1 - 1-1/2"	74,000	105,000	50	19 - 30 HRC
8	1/4 - 1-1/2"	120,000	150,000	58.6	33 - 39 HRC

* Proof Load Testing applies only to stress relieved products of this grade. Consult SAE J429 or Nucor Technical Personnel for more information.

** For bolts & screws 6" or shorter in length. Grade 1 requirements apply to parts longer than 6".

Applications

Cap Screws can be used in tapped holes or with a nut (like a bolt). Most designs using Cap Screws, where a clamp load is specified, require the Cap Screw to be tightened to about 75% of the proof load to ensure a safe working range. The single shear strength of a Cap Screw is about 60% of the ultimate tensile strength times the shear area, so, working loads should be lower than this breaking strength. The fatigue strength of Cap Screws as measured by the endurance limit will vary widely depending upon the amplitude, frequency, and type of applied load. Endurance limits of 10-20% of the tensile strength have been reported for high strength Cap Screws.

Suggested Torque Values

All torque/tension relationships should be viewed with a cautious eye since no one table can indicate the range of conditions expected to be experienced by a fastener. Torque is only an indirect indication of tension. The torque value to use in an application is best obtained by using a calibrated torque wrench (or transducer) and a Skidmore-Wilhelm type load indicating device to equate actual torque to desired tension. Nearly all of the torque/tension tables which have been developed, including the one shown in Table 3, are based on the following formula:

$T=(k*d*P)/12$ where T = Torque (ft-lbs), d = nominal diameter (inches), P = Tension (lbs), and k is the "torque coefficient" or "nut factor" (dimensionless)

The value of k is a dimensionless "fudge factor" which includes variables such as friction, thread conditions, etc. The value of k can range from 0.10 for a well lubricated connection to greater than 0.30 for a rusted assembly. Normally, k is approximately 0.20 for plain steel (increase by about 10% for zinc plated and decrease by about 25% for parts which have been well lubricated). The torques shown below represent starting values for plain capscrews (k = 0.20) at 60% - 90% of the proof load tension:

Table 3 – Suggested Torque Values and Clamp Loads for SAE Grades 2, 5, & 8 Cap Screws

NOMINAL DIAMETER AND TPI (INCHES)	THREAD STRESS AREA (SQ-IN)	SAE GRADE 2		SAE GRADE 5		SAE GRADE 8	
		CLAMP LOAD 60-90% PROOF (POUNDS)	TIGHTENING TORQUE (FT-LBS)	CLAMP LOAD 60-90% PROOF (POUNDS)	TIGHTENING TORQUE (FT-LBS)	CLAMP LOAD 60-90% PROOF (POUNDS)	TIGHTENING TORQUE (FT-LBS)
1/4 - 20	0.0318	1,049 - 1,574	4 - 7	1,622 - 2,433	7 - 10	2,290 - 3,434	10 - 14
1/4 - 28	0.0364	1,201 - 1,802	5 - 8	1,856 - 2,785	8 - 12	2,2621 - 3,931	11 - 16
5/16 - 18	0.0524	1,729 - 2,594	9 - 14	2,672 - 4,009	14 - 21	3,773 - 5,659	20 - 29
5/16 - 24	0.0580	1,914 - 2,871	10 - 15	2,958 - 4,437	15 - 23	4,176 - 6,264	22 - 33
3/8 - 16	0.0775	2,558 - 3,868	16 - 24	3,953 - 5,929	25 - 37	5,580 - 8,370	35 - 52
3/8 - 24	0.0878	2,897 - 4,346	18 - 27	4,478 - 6,717	28 - 42	6,322 - 9,482	40 - 59
7/16 - 14	0.1063	3,508 - 5,262	26 - 38	5,421 - 8,132	40 - 59	7,654 - 11,480	56 - 84
7/16 - 20	0.1187	3,917 - 5,876	29 - 43	6,054 - 9,081	44 - 66	8,546 - 12,820	62 - 93
1/2 - 13	0.1419	4,683 - 7,024	39 - 59	7,237 - 10,855	60 - 90	10,217 - 15,325	85 - 128
1/2 - 20	0.1599	5,277 - 7,915	44 - 66	8,155 - 12,232	68 - 102	11,513 - 17,269	96 - 144
9/16 - 12	0.1820	6,006 - 9,009	56 - 84	9,282 - 13,923	87 - 131	13,104 - 19,656	123 - 184
9/16 - 18	0.2030	6,699 - 10,049	63 - 94	10,353 - 15,530	97 - 146	14,616 - 21,924	137 - 206
5/8 - 11	0.2260	7,458 - 11,187	78 - 117	11,526 - 17,289	120 - 180	16,272 - 24,408	170 - 254
5/8 - 18	0.2560	8,448 - 12,672	88 - 132	13,056 - 19,584	136 - 204	18,432 - 27,648	192 - 288
3/4 - 10	0.3340	11,022 - 16,533	138 - 207	17,034 - 25,551	213 - 319	24,048 - 36,072	301 - 451
3/4 - 16	0.3730	12,309 - 18,464	154 - 231	19,023 - 28,535	238 - 357	26,856 - 40,284	336 - 504
7/8 - 9	0.4620	15,246 - 22,869	222 - 334	23,562 - 35,343	344 - 515	33,264 - 49,896	485 - 728
7/8 - 14	0.5090	16,797 - 25,196	245 - 367	25,959 - 38,939	379 - 568	36,648 - 54,972	534 - 802
1 - 8	0.6060	19,998 - 29,997	333 - 500	30,906 - 46,359	515 - 773	43,632 - 65,448	727 - 1,091
1 - 14	0.6790	22,407 - 33,611	373 - 560	34,629 - 51,944	577 - 866	48,888 - 73,332	815 - 1,222
1-1/8 - 7	0.7630	25,179 - 37,769	472 - 708	33,877 - 50,816	635 - 953	54,936 - 82,404	1,030 - 1,545
1-1/8 - 12	0.8560	28,248 - 42,372	530 - 794	38,006 - 57,010	713 - 1,069	61,632 - 92,448	1,156 - 1,733
1-1/4 - 7	0.9690	31,977 - 47,966	666 - 999	43,024 - 64,535	896 - 1,344	69,768 - 104,652	1,454 - 2,180
1-1/4 - 12	1.0730	35,409 - 53,114	738 - 1,107	47,641 - 71,462	993 - 1,489	77,256 - 115,884	1,610 - 2,414

Nucor Fastener has the equipment, quality, systems, expertise, sources & people to meet your Hex Head Cap Screw needs.

TODAY, THAT LITTLE "n" MEANS BIG THINGS!

Table 2 – SAE J429 Proof Load and Tensile Strength Requirements Coarse Thread Series – UNC

NOMINAL DIA OF PRODUCTS AND THREADS PER INCH	SAE GRADE 2		SAE GRADE 5		SAE GRADE 8	
	PROOF LOAD, LB.	TENSILE STRENGTH MIN, LB.	PROOF LOAD, LB.	TENSILE STRENGTH MIN, LB.	PROOF LOAD, LB.	TENSILE STRENGTH MIN, LB.
1/4 - 20	1,750	2,350	2,700	3,800	3,800	4,750
5/16 - 18	2,900	3,900	4,450	6,300	6,300	7,850
3/8 - 16	4,250	5,750	6,600	9,300	9,300	11,600
7/16 - 14	5,850	7,850	9,050	12,800	12,800	15,900
1/2 - 13	7,800	10,500	12,100	17,000	17,000	21,300
9/16 - 12	10,000	13,500	15,500	21,800	21,800	27,300
5/8 - 11	12,400	16,700	19,200	27,100	27,100	33,900
3/4 - 10	18,400	24,700	28,400	40,100	40,100	50,100
7/8 - 9	15,200	27,700	39,300	55,400	55,400	69,300
1 - 8	20,000	36,400	51,500	72,700	72,700	90,900
1-1/8 - 7	25,200	45,800	56,500	80,100	91,600	114,400
1-1/4 - 7	32,000	58,100	71,700	101,700	116,300	145,400
1-3/8 - 6	38,100	69,300	85,500	121,300	138,600	173,200
1-1/2 - 6	46,400	84,300	104,000	147,500	168,600	210,800

Fine Thread Series – UNF

NOMINAL DIA OF PRODUCTS AND THREADS PER INCH	SAE GRADE 2		SAE GRADE 5		SAE GRADE 8	
	PROOF LOAD, LB.	TENSILE STRENGTH MIN, LB.	PROOF LOAD, LB.	TENSILE STRENGTH MIN, LB.	PROOF LOAD, LB.	TENSILE STRENGTH MIN, LB.
1/4 - 28	2,000	2,700	3,100	4,350	4,350	5,450
5/16 - 24	3,200	4,300	4,900	6,950	6,950	8,700
3/8 - 24	4,800	6,500	7,450	10,500	10,500	13,200
7/16 - 20	6,550	8,800	10,100	14,200	14,200	17,800
1/ - 20	8,800	11,800	13,600	19,200	19,200	24,000
9/16 - 18	11,200	15,000	17,300	24,400	24,400	30,400
5/8 - 18	14,100	18,900	21,800	30,700	30,700	38,400
3/4 - 16	20,500	27,600	31,700	44,800	44,800	56,000
7/8 - 14	16,800	30,500	43,300	61,100	61,100	76,400
1 - 12	21,900	39,800	56,400	79,600	79,600	99,400
1 - 14 uns	22,400	40,700	57,700	81,500	81,500	101,900
1-1/8 - 12	28,200	51,400	63,300	89,900	102,700	128,400
1-1/4 - 12	35,400	64,400	79,400	112,700	128,800	161,000
1-3/8 - 12	43,400	78,900	97,300	138,100	157,800	197,200
1-1/2 - 12	52,200	94,900	117,000	166,000	189,700	237,200

Table 4 Dimensions of Hex Cap Screws

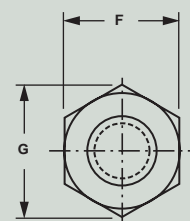
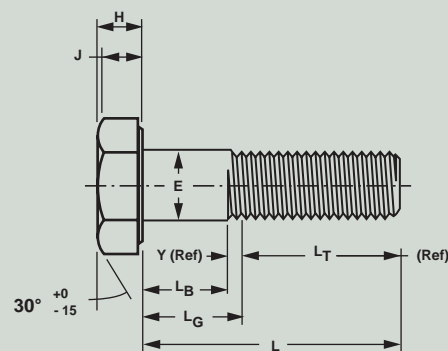

NOMINAL SIZE OR BASIC PRODUCT DIAMETER		E		F			G		H			I	L		Y	RUNOUT OF BEARING SURFACE FIM
		BODY DIAMETER		WIDTH ACROSS FLATS			WIDTH ACROSS CORNERS		HEIGHT			WRENCHING HEIGHT	THREAD LENGTH FOR SCREW LIGHTS		TRANSITION THREAD LENGTH	
		MAX.	MIN.	BASIC	MAX.	MIN.	MAX.	MIN.	BASIC	MAX.	MIN.	MIN.	6 IN. AND SHORTER	OVER 6 IN.	MAX.	
1/4	0.2500	0.2500	0.2450	7 / 16	0.438	0.428	0.505	0.488	5/32	0.163	0.150	0.106	0.750	1.000	0.250	0.010
5/16	0.3125	0.3125	0.3065	1 / 2	0.500	0.489	0.577	0.557	13/64	0.211	0.195	0.140	0.875	1.125	0.278	0.011
3/8	0.3750	0.3750	0.3690	9 / 16	0.562	0.551	0.650	0.628	15/64	0.243	0.226	0.160	1.000	1.250	0.312	0.012
7/16	0.4375	0.4375	0.4305	5 / 8	0.625	0.612	0.722	0.698	9/32	0.291	0.272	0.195	1.125	1.375	0.357	0.013
1/2	0.5000	0.5000	0.4930	3 / 4	0.750	0.736	0.866	0.840	5/16	0.323	0.302	0.215	1.250	1.500	0.385	0.014
9/16	0.5625	0.5625	0.5545	13/16	0.812	0.798	0.938	0.910	23/64	0.371	0.348	0.250	1.375	1.625	0.417	0.015
5/8	0.6250	0.6250	0.6170	15/16	0.938	0.922	1.083	1.051	25/64	0.403	0.378	0.269	1.500	1.750	0.455	0.017
3/4	0.7500	0.7500	0.7410	1-1/8	1.125	1.100	1.299	1.254	15/32	0.483	0.455	0.324	1.750	2.000	0.500	0.020
7/8	0.8750	0.8750	0.8660	1-5/16	1.312	1.285	1.516	1.465	35/64	0.563	0.531	0.378	2.000	2.250	0.556	0.023
1	1.0000	1.0000	0.9900	1-1/2	1.500	1.469	1.732	1.675	39/64	0.627	0.591	0.416	2.250	2.500	0.625	0.026
1-1/8	1.1250	1.1250	1.1140	1-11/16	1.688	1.631	1.949	1.859	11/16	0.718	0.658	0.461	2.500	2.750	0.714	0.029
1-1/4	1.2500	1.2500	1.2390	1-7/8	1.875	1.812	2.165	2.066	25/32	0.813	0.749	0.530	2.750	3.000	0.714	0.033
1-3/8	1.3750	1.3750	1.3630	2-1/16	2.062	1.994	2.382	2.273	27/32	0.878	0.810	0.569	3.000	3.250	0.833	0.036
1-1/2	1.5000	1.5000	1.4880	2-1/4	2.230	2.175	2.598	2.480	1-5/16	0.974	0.902	0.640	3.250	3.500	0.833	0.039

