



TRU-TENSION® FASTENING SYSTEM

NUCOR FASTENER

TECHNICAL DATA SHEET

Tru-Tension® Structural Fasteners are a fastening system offering many advantages over conventional structural bolt systems. Lower costs for bolting installation and inspection can add up to tremendous savings when compared to conventional structural bolting systems.

In addition to the features offered by the Tru-Tension® Fastening System, you get the added confidence knowing that Tru-Tension® Assemblies come from Nucor Fastener, the leading manufacturer of structural fasteners in the United States. When buying structural products from Nucor Fastener, you are selling fasteners that are formed domestically in our ISO9001 registered facility; from steel melted and rolled in the U.S.A.; and tested in our A2LA Accredited in-house laboratory. Certifications are always available to the purchaser, including original steel certifications.

Tru-Tension® Structural Assemblies are installed with a quiet, light weight electric installation tool which reduces operator fatigue and eliminates problems in compliance with OSHA Noise Regulations encountered when using pneumatic impact wrenches. Since the bolt is calibrated so the spline tip twists-off when the proper bolt tension is achieved, there is no need to rely on a calibrated wrench or on an operator's skill to correctly install the bolt to the proper tension. Tru-Tension® Assemblies feature a specially developed lubricant system which provides consistent assembly properties over a wide range of installation conditions. The correct fastener tension in compliance with AISC Bolting Specifications is achieved in the Tru-Tension® Assembly, because the bolt assembly is factory calibrated. Evidence of proper tension can be accomplished by visual inspection to see that the spline has twisted off, thus reducing the expense of more costly bolting inspections.



Dome Head Tru-Tension® Fasteners From Nucor Fastener

Tru-Tension® Assemblies are manufactured to ASTM F1852 (A325 equivalent) or ASTM F2280 (A490 equivalent) standards in the United States using domestically produced steel. Each Tru-Tension® Bolt is pre-assembled with an ASTM F436 Hardened Washer and a Heavy Hex Nut. The lots are fully traceable from raw material through to finished product. Each lot is fully tested by our A2LA Accredited Laboratory and certified test reports are included with each shipment. The bolts are supplied as ASTM F1852 ("Standard Specification for "Twist Off" Type Tension Control Structural Bolt/Nut/Washer Assemblies, Steel, Heat Treated, 120/105 ksi Minimum Tensile Strength") or ASTM F2280 ("Standard Specification for "Twist Off" Type Tension Control Structural Bolt/Nut/Washer Assemblies, Steel, Heat Treated, 150 ksi Minimum Tensile Strength") with a dome (round head) or heavy hex head configuration. The mechanical properties, threads, and thread length are the same as for Heavy Hex Structural Bolts. The diagram and table (below) show the dimensions of the dome head configuration used by Nucor Fastener. The heavy hex head configuration can be supplied by special order.

Dimensions for Tru-Tension® Bolts

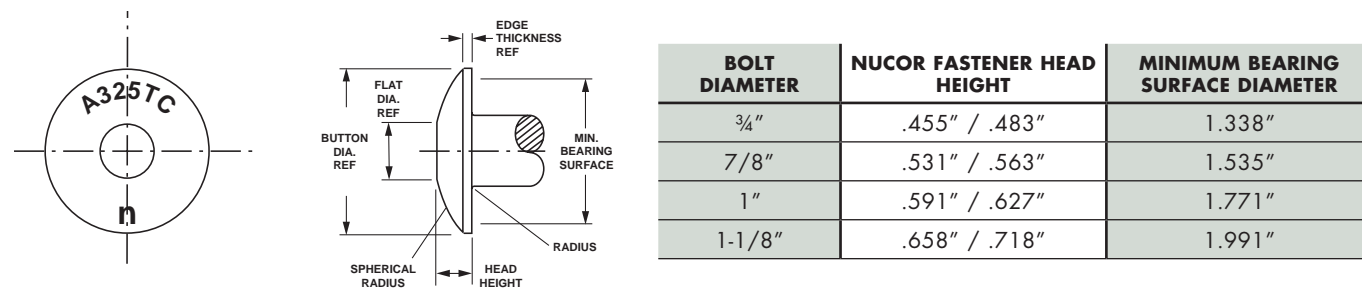

The correct fastener tension, in compliance with AISC/RCSC Bolting Specifications (covered in the "Specification for Structural Joints Using ASTM A325 or A490 Bolts"), is assured by proper control of the dimensions (especially the groove diameter of the spline) and friction conditions.

Advantages And Features Of Tru-Tension® Fasteners From Nucor

Meets or Exceeds AISC Tension Requirements

- Provides dependability by consistently exceeding the minimum AISC bolt installed tensions.
- Fully tested and certified assemblies.
- Installation is completed without putting torsion into bolt length – only the bolt length between the nut and splined tip is in torsion – the balance of the bolt is in tension, providing more consistent and greater available bolt tensions.

Buy with Confidence

- All Products 100% Made in USA.
- Large Inventory.
- Capable of Producing a Full Range of Product Diameters and Lengths.
- World Class Customer Service and Technical Support.
- Full Traceability, just like all other Nucor Fastener Products.

Easy to Install

- Can be used anywhere a standard structural bolt is used (provided that it is acceptable to the responsible designer or project engineer).
- Does not depend on tool calibration or operator skill for proper assembly.

- Lightweight installation tool.
 - Electric tools are powered by 115 or 220 volts.
 - Quiet installation system.
- Reduced operator fatigue.
 - Non-Impacting Electric Tool.
 - No external reaction moment (to twisting).
 - Easier to setup and move than air compressor and air lines.
- Shipped assembled (nut, bolt & washer) in sealed metal kegs. No field nutting required.
- Pre-assembled fasteners that ensure matched sets – saves assembly time.

Allows For Rapid Visual Inspection

- Eliminates operator error during assembly.
- Can visually inspect for proper installation by seeing that the spline has twisted off.
- No need for expensive installation tool calibration.

Reduced Cost of Installation

- Save money in installation.
 - Increased installation speed (typically 2 to 3 times more bolts installed per man-hour).
 - Lower inspection costs (quick visual check vs. typical rechecking of – 5% of all joints).
- Pre-assembled fasteners that ensure matched sets – saves assembly time.
- One man, one side assembly (no need for a back-up man).
- Tru-Tension® Bolting can save money in shop fabrication by using bolted web stiffeners and gussets rather than welding. Successful bolt installation does not require highly skilled labor.

Typical Expected Cost Savings

The following information is an overview of typical savings that may be possible when using Tru-Tension® Fasteners instead of a standard A325 Bolt with a nut and washer.

INSTALLATION CONDITION	REGULAR A325 BOLT-NUT-WASHER	TRU-TENSION® FASTENER
Purchase Fasteners	Buy Bolt, Nut, and Washers Separately. Come in separate containers. Maintain separate test reports, lot numbers and documentation.	Buy Tru-Tension® Fastener. Come pre-assembled in 1 can. One source for test reports and documentation.
Pre-Testing	Test each combination of bolt-nut-washer in load cell. Maintain this combination in the field. Test daily for calibrated wrench tightening.	Run confirmation testing in load cell using standard electric wrench.
Equipment and Tools (enough to do the job)	Impact Wrenches (~35# each) and air compressors/air lines. Load Cell. Calibrated Torque Wrench.	Shear Wrenches (~15# each) and electric generator. Load Cell.
Pre-Tensioning	Each connection, starting from most rigid section.	Each connection, starting from most rigid section.
Installation	Typically ~24/40 bolts/man-hour.	Typically ~60/100 bolts/man-hour.
Inspection	Typically, could expect to recheck 5-10% of the bolts by manual torque wrench.	Visual inspection is normally all that is required.

The cost of the first three rows will vary by project. The cost of additional paperwork and maintenance of the individual containers can be expected to take up to ½ hour per lot of received material. Pre-testing is very quick and simple for Tru-Tension® products. If calibrated torque wrenches are used for installation, pre-testing must be done on a daily basis (resulting in several additional hours over the course of the project). Also, tool calibration is required for installation by torque.

Pre-tensioning operations are the same for all high strength structural bolts. The snug tight condition is required for all connections prior to final tightening.

Final installation is typically two to three times faster with Tru-Tension® Fasteners. At typical hourly rates of \$75/hour and an average installation of 30 bolts/man-hour for separate components, the following savings can be expected:

	1,000 BOLTS	5,000 BOLTS	10,000 BOLTS	25,000 BOLTS	50,000 BOLTS
Two Times Faster	\$1,250	\$6,250	\$12,500	\$31,250	\$62,500
Three Times Faster	\$1,670	\$8,350	\$16,700	\$41,750	\$83,500

The direct labor installation cost savings is approximately \$1.25/bolt, not counting the savings for inspection costs after final installation (which will vary based on testing scheme, but would likely add more than \$0.15/bolt to the total cost).

Handling, Storage And Pre-Installation

Handling and Storage

The following information, from the AISC/RCSC "Specification for Structural Joints Using ASTM A325 or A490 Bolts", is applicable to all high strength fasteners, including Tru-Tension® products: "Fasteners shall be protected from dirt and moisture at the job site. Only as many fasteners as are anticipated to be installed and tightened during a work shift shall be taken from protected storage. Fasteners not used shall be returned to protected storage at the end of the shift. Fasteners shall not be cleaned of lubricant that is present in as-delivered condition." The last point is very important for Tru-Tension® Fasteners. The lubrication condition on the fasteners cannot be modified, that is, never clean, strip or add additional lubrication to the product. Opened cans should be stored indoors, protected from the elements, to prevent environmental contamination from rain, dirt, rust, etc...

Use of Washers

The ASTM F436 Washer included with the tension control assembly must be placed under the nut in all cases. Refer to section 6 of the RCSC "Specification for Structural Joints Using ASTM A325 or A490 Bolts" for additional requirements governing the use of additional washers.

Snug Tightening

All of the fasteners in the connection must be brought to a snug tight condition prior to final tightening. This method will prevent interactions between bolts as additional bolts are tightened.

As always, fasteners should be tightened in sequence from the most rigid section outward. In some cases, this may require more than a single cycle of systematic tightening or tightening in a pattern.

Pre-Installation Testing

Representative samples should be checked at the job site in a device capable of indicating bolt tension. The testing should demonstrate that the system develops the proper tension, prior to installation, in accordance with RCSC recommendations.

How the Tru-Tension® System Works

Tru-Tension® Fasteners are designed to be installed with various types of lightweight portable electric wrenches specifically intended for use with this style of structural fasteners. They can be utilized for any applications where A325 or A490 – Type I or Type III (weathering steel) hex bolts are specified. The installation tool has an inner socket which engages the spline tip of the bolt, while the outer socket engages the nut. The outer socket rotates the nut relative to the bolt spline, and when the tension is sufficient in the fastener, the spline tip simply twists-off, leaving the tightened bolt correctly installed in the connection.

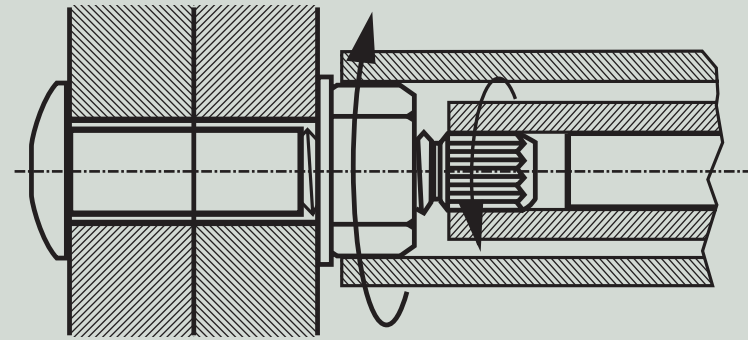

Determination of Tru-Tension® Length

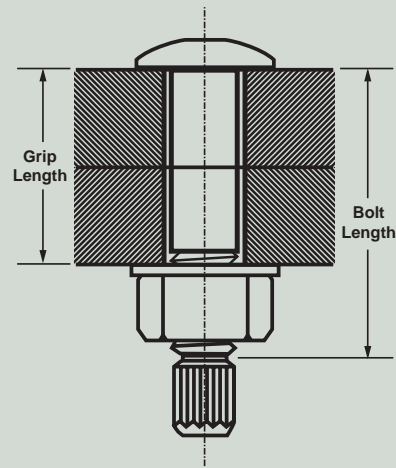

BOLT DIA. (IN.)	TO DETERMINE BOLT LENGTH, ADD NOTED AMOUNT TO THE STEEL TO STEEL GRIP AND ROUND UP TO THE NEXT STD BOLT LENGTH. (IN.)
5/8	7/8
3/4	1
7/8	1 1/8
1	1 1/4
1 1/8	1 1/2

Grip Length is defined as the total thickness of all connected material, exclusive of washers. Each ASTM F436 washer used is 5/32 in. thick, use 5/16 in. for each beveled washer used.

Structural Fastener Tension

Fastener tension test requirements for slip-critical connections and connections subject to direct tension.

NOMINAL BOLT SIZE (IN.)	MINIMUM TENSION ¹ IN 1000'S OF POUNDS (KIPS)	
	A325 BOLTS & F1852 ASSY	A490 BOLTS & F2280 ASSY
5/8	20.0	25.2
3/4	29.4	36.8
7/8	41.0	51.5
1	53.6	67.2
1 1/8	58.8	84.0

¹Equal to 70 percent of specified minimum tensile strengths of bolts (as specified in ASTM Specifications for test of full size A325 and A490 bolts with UNC threads loaded in axial tension). May be rounded to nearest 1000 lbs. (chart includes additional 5% per AISC spec.)

Installation Procedures

1. Nut and washer identification markings should face away from the connection. All fasteners in the connection should be snug tight.
2. Fit inner socket over the grooved spline and push the wrench slightly, then engage the outer socket over the nut.
3. Start the wrench. The outer socket rotates the nut relative to the bolt during tightening, and the bolt will be tightened until the required bolt tension is reached. At this point the splined tip shears off.
4. When the installation is complete, remove the socket from the nut and depress the ejection lever to discharge the sheared spline from the inner socket of the wrench.

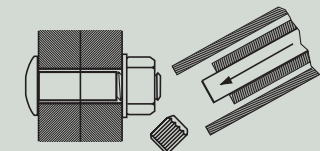
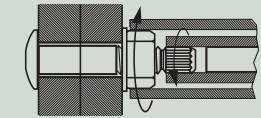
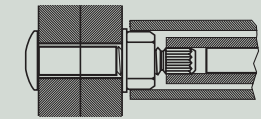
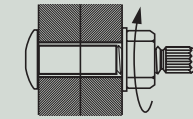

Nucor Black Kegs are really "Green"! With an Average Recycled Content of 99%, Nucor Fastener products qualify for "Green Building" applications or LEED® rated projects. Just as you would expect from Nucor, the largest recycler in North America. It's our Nature!

Nucor Fastener has the equipment, quality, systems, expertise, sources, people and distributor network to supply your Tru-Tension® Fastening System needs!

TODAY, THAT LITTLE "n" MEANS BIG THINGS!

This Technical Data Sheet is subject to change without prior notification.

